

Service points are grouped on right side.

Since 1960, Alaska Diesel Electric's success has been based on our obsession with innovative, application specific design, quality control and unit reliability. This has made our Northern Lights sets the recognized standard of the industry.

The NL445T2 meets this high standard. It combines a high torque, low rpm industrial diesel, a conservatively rated

generator end and your choice of controls. The resulting power system gives you economical prime power or reliable standby protection. A system designed to pick up 100% of the rated load with minimal voltage dip and quick recovery.

The NL445T2 features a John Deere **PowerTech** engine designed to meet EPA, CARB and EEC emissions standards. It is

also quieter, lighter and more economical.

The set's quality allows us to back it with an industry-leading one year, unlimited-hour, warranty. This, along with sole-source supply, assures you of quick and total product support.

Special needs? Let our engineers use the NL445T2 as a foundation for a custom set designed for your power requirements.

STANDARD FEATURES & OPTIONS

Heavy Duty Engine

- John Deere, PowerTech liquid cooled, in-line, 4 cylinder, diesel engine designed to produce peak torque at low RPM.
- Turbocharged engine for increased performance and fuel economy.
- Replaceable, liquid cooled cylinder liners for long life and low rebuild costs.
- Liquid cooled with radiator. Poly-vee single belt fan drive system. Pusher cooling fan has hand guard to protect operator. Steel radiator shroud standard.
- Four cycle operation and direct injection for fuel economy and low noise.
- Engine mounted fuel filter with drain valve on canister. Toolless element change.
- Fuel lines routed to fuel manifold on base frame for easy installation.
- Full flow, spin-on oil filter with bypass.
- Jacketwater engine oil cooler reduces heat and thermal breakdown of lube oil.
- Oil spray piston cooling.
- High ring pistons with patented combustion bowl maximizes operating efficiencies and low emissions.
- Shipped with lube oil.
- Large, dry element, industrial air filter protects engine in dusty environment.
- 12 volt system with starter motor, battery charging alternator and regulator.
- Low oil pressure and high coolant temperature shutdown system.

- Every engine is dyno tested. Every set is load tested with controls installed.
- Two gear-driven balance shafts rotate at twice engine speed counteracting vertical forces for smooth operation.
- Control panel with NEMA 1 enclosure, oil pressure and coolant temperature gauges, DC volt and engine hour meters, and engine control switches is standard equipment.

Conservative AC Generator

- Northern Lights, direct coupled, single bearing, 12 lead, reconnectable generators are torsionally matched with engine.
- Brushless design is maintenance free.
- Generators meet or exceed NEMA and BS standards with class H insulation, accessible diodes, oversized ball bearings and conservative 105°C temperature rise at prime rating and 130°C at standby.
- Automatic voltage regulators give quick response, excitation support and stable paralleling. Voltage is regulated to $\pm 1.5\%$ RMS from no load to full load.

Special Set Features

- Heavy duty, steel base frames.
- Long life white enamel paint for better service visibility.
- Center bonded vibration isolation mounts reduce noise and vibration.
- Parts and operator's manuals standard.

Integrated options

- ▼ Control Panels
 - AC & DC monitoring panel
 - PLC controlled auto-start panel
 - 7 light monitoring module
 - 12 light monitoring module
 - Stop-Start panels
- Manual transfer switches
- Automatic transfer switches
- Circuit breakers
- Paralleling switchgear
- ▼ Alarms and Shutdown Systems
 - Overspeed shutdown
 - Low coolant level shutdown
 - Low lube oil level shutdown
- ▼ Exhaust Muffler System
 - Residential
 - Critical
 - Compact
- ▼ Heaters and Tanks
 - Jacket water heater
 - Lube oil heaters
 - Day tank
 - Fuel tank
 - Dry sump lube oil tank
- ▼ Enclosures
 - Weather enclosure
 - Arctic environment enclosures
 - Sound attenuation enclosures
 - Trailer mounted enclosure
- Custom painting
- Export crating
- Certified test results
- Heat recovery systems

NL445T2 SPECIFICATIONS

	60 Hz Prime	60 Hz Standby	50 Hz Prime	50 Hz Standby		60 Hz Prime	60 Hz Standby	50 Hz Prime	50 Hz Standby
AC Output¹					Fuel Consumption³				
kW	66	70	56	59	Full load g/hr (L/hr)	4.9 (18.6)	5.4 (20.5)	4.2 (15.8)	4.7 (17.7)
KVA	82.5	87.5	70	73.75	3/4 load g/hr (L/hr)	3.8 (14.4)	4.2 (15.8)	3.1 (11.8)	3.5 (13.1)
Hertz	60	60	50	50	1/2 load g/hr (L/hr)	2.7 (10.1)	2.9 (11.1)	2.2 (8.3)	2.4 (9.1)
RPM	1800	1800	1500	1500	Full Max fuel flow g(L)/hr	29.5 (111.6)	29.5 (111.6)	28.5 (108)	28.5 (108)
Voltage regulation	± 1.5%	± 1.5%	± 1.5%	± 1.5%	Fuel inlet & return inch NPT	1/4	1/4	1/4	1/4
Std Phase (optional) ²	3 (1)	3 (1)	3 (1)	3 (1)	Max fuel lift in(m)	39 (1)	39 (1)	39 (1)	39 (1)
Std. low volt (WYE) amps	120/208	120/208	127/220	127/220	Air				
Std. high volt (WYE) amps	277/480	277/480	220/380	220/380	Combustion air cfm (m ³ /m)	191 (5.4)	198 (5.6)	141 (4.0)	148 (4.2)
Optional Voltage (WYE)	127/220 thru 254/480		110/190 thru 240/416		Generator cooling air cfm (m ³ /m)	595 (16.8)	595 (16.8)	458 (12.9)	458 (12.9)
Optional Voltage (Delta)	120/240	120/240	110/220	110/220	Radiator cooling air cfm (m ³ /m)	3970 (112)	3970 (112)	2974 (84)	2974 (84)
Motor Starting					Max restriction radiator (static)	2in (50 mm) H ₂ O		2in (50 mm) H ₂ O	
Max. KVA @ 25% Dip	205	205	180	180	Cooling and Lubrication				
Engine					Heat rejected to coolant btu/min	2445	2730	2161	2389
Deere Inline 4 cylinder	Model 445T1		Model 445D1		Lube oil capacity US gal (ltr)	3.25 (12.2)	3.25 (12.2)	3.25 (12.2)	3.25 (12.2)
Displacement in ³ (ltr)	276 (4.5 ltr)		276 (4.5 ltr)		Exhaust				
Bore/Stroke in (mm)	4.19/5.0 (106/127)		4.19/5.0 (106/127)		Exhaust gas flow cfm (m ³ /M)	487 (13.8)	522 (14.8)	374 (10.6)	409 (11.6)
BHP with fan	102	113	84	94	Max exhaust temp °F (°C)	946 (508)	1000 (538)	979 (526)	1050 (565)
					Max back pressure in (mm) H ₂ O	30 (762)	30 (762)	30 (762)	30 (762)
					Min exhaust outlet in(mm)	4 (101.6)	4 (101.6)	4 (101.6)	4 (101.6)

- Notes:**
- Deratings: 3% per 1000 feet over 500ft above sea level. 5% for every 10° over 77° F.
 - Three phase rated at 0.8 power factory. Single phase rated at 1.0 PF.
 - US gallons per hour. Actual fuel consumption will vary higher or lower depending on operating conditions.

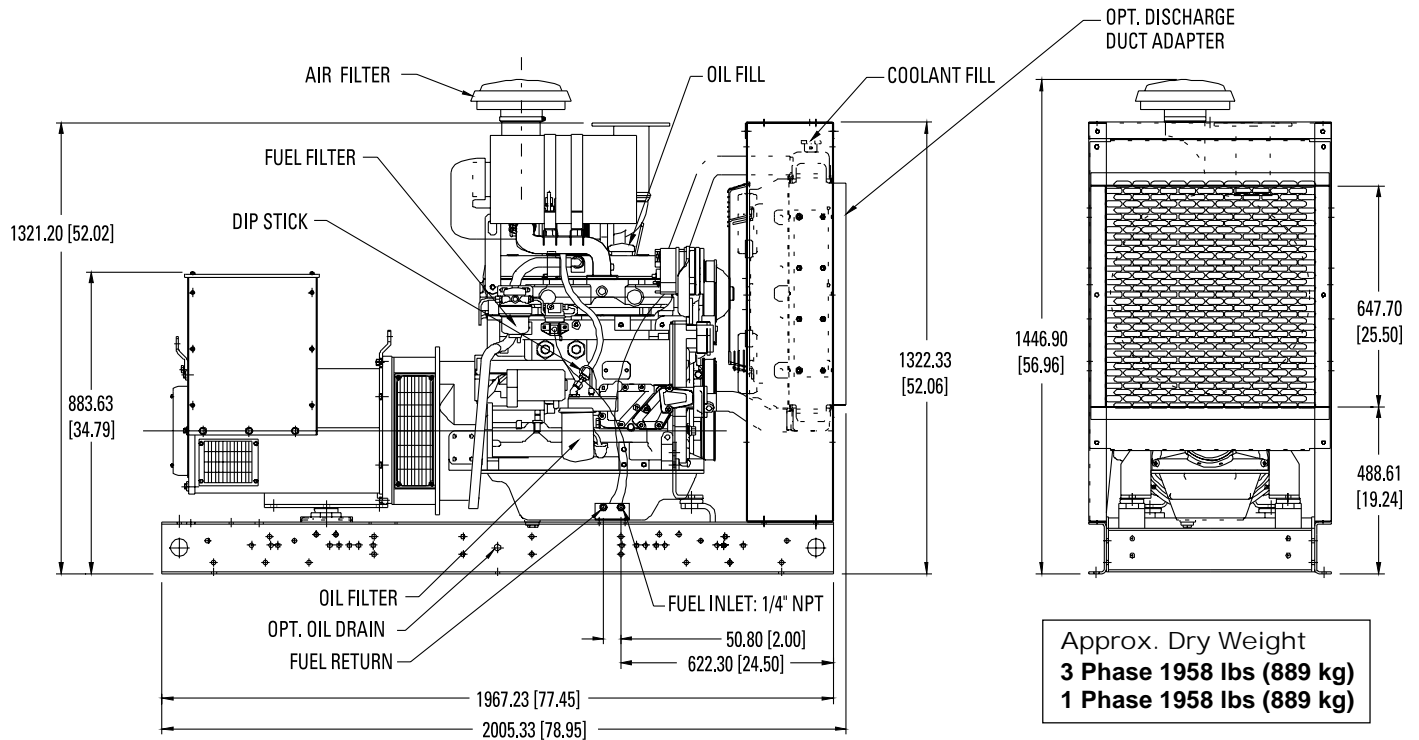

Drawing number: C-3709 Dimensions subject to change without notice. Contact dealer for installation drawings.



Northern Lights are mfg. by: Alaska Diesel Electric, Inc.
4420 14th Ave. NW, P.O. Box 70543, Seattle, WA 98107 Tel: (206) 789-3880 • Fax: (206) 782-5455
www.northern-lights.com • E-mail: ade@northern-lights.com
Specifications, materials and dimensions are subject to change without notice.
© 1998 Alaska Diesel Electric, Inc. All rights reserved. Litho in U.S.A. L537 2/98

DEALER