

This new Northern Lights 32 kW marine set combines the clean, quiet Luger 984 diesel with a shorter, lighter 300K series generator end.

The Luger engine that powers the M984K features reentrant pistons and other advanced combustion features that reduce exhaust smoke to the lowest levels. This remarkably clean-running set minimizes environmental pollution and increases the enjoyment of all on board. It's a breath of fresh air for neighboring vessels, too.

Clean and quiet, the M984K has the latest in noise and vibration abatement features. Double wall oil pan, isolated valve cover, helical

No service points on this side lets you install the set close to a bulkhead. Features: Liquid cooled cast iron exhaust elbow. 12 volt starter and alternator.

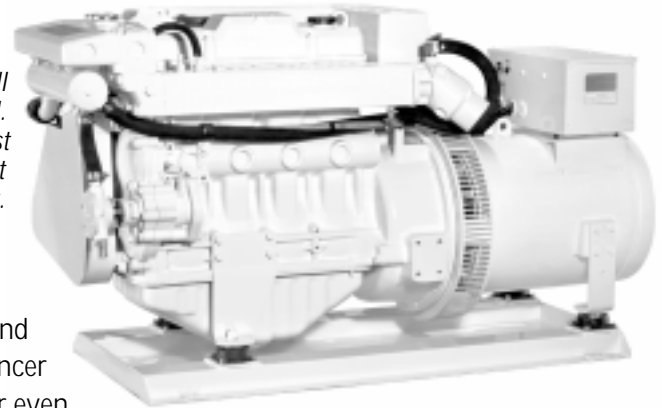

timing gears, soft mounts and a noise maze air intake silencer all reduce engine noise. For even quieter operation, consider an optional sound shield.

The M984K fits. At 54.57 inches long it is over 4 inches shorter than before. Compact and light weight, the M984K weighs in at only 1219 lbs. (553 kg).

Versatile too. Need hydraulic power? Add a front power take-off with an electric clutch. At the touch of a switch you have up to 42 horsepower

for bow thrusters, roller furling, anchor winches and other deck gear.

To all this add one-side service, plug-in instrument panels, safety shut-downs, polyurethane paint and a self-venting fuel system. In the end you have more than a great generator. You have the confidence that comes with owning the very best... a Northern Lights.

- Junction box contains AC terminal strip, solid state AC automatic voltage regulator with circuit breaker and DC system circuit breaker.
- Cast intake manifold with washable air filter silencer.
- Spin-on oil and fuel filters.
- Bosch-type in-line injection pump with hand primer.
- Large, easy fill expansion tank.
- DC wire harness with plug-ins protected by plastic loom.
- Northern Lights brushless, direct coupled generator.
- Four platform vibration isolation mounts for smooth operation.
- Intake silencer for quiet operation.
- Fuel inlet and return manifold.
- Double wall oil pan for quiet operation.
- Welded steel base with drip pan keeps engine room clean.
- Top and side oil fills.
- Gear driven, Jabsco seawater pump. No drive belt. Ceramic seals.
- Beltguard.
- Battery charging 12 volt alternator and solid state DC regulator.

M984K Specifications

AC Output¹

32 kW60 Hz, 1800 RPM, 1 Ph, 1.0 PF,
120-240 V/133 A, 120 V/267 A
25 kW50 Hz, 1500 RPM, 1 Ph, 1.0 PF,
220 V/114 A, 110 V/220 A

Voltage regulation±1%

Engine

TypeL984
Displacement212 in³ (3.47 ltr)
Bore/Stroke3.85/4.5 in (98/115mm)
HP @ 1800 RPM48
Approx. fuel use @ full load².....2.6 gph (9.8 lph)
@ half load².....1.4 gph (5.3 lph)

Installation Data

Wet exhaust elbow3" (76mm) OD
Raw water inlets0.75" (20mm) OD
Fuel inlet and return1/4" NPT

Weight

Approx. dry weight1219 lbs (553 kg)

1. Based on SAE J1995 and ISO 3046. 2. Actual fuel consumption will vary depending on operating conditions.

Dimensional Data

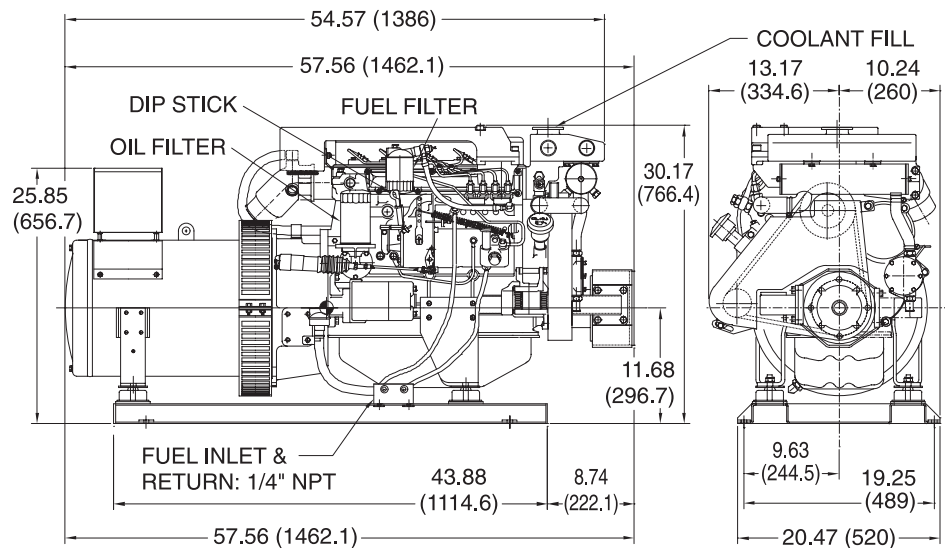

Main dimensions given in inches (mm). Dimensions subject to change without notice.

M984K Features and Benefits

Engine Block

- Luger, four cycle, 4 cylinder liquid cooled, naturally aspirated, overhead valve marine diesel based on an industrial engine block.
- Crankshaft is induction hardened, forged carbon steel; stronger than cast iron. Eight point balancing for smoothness.
- Helical cut and ground, carbon steel timing and PTO gears reduce noise.
- Cross flow head for efficient breathing.
- Sandwich oil pan reduces noise.

Cooling System

- Freshwater cooling system in heat exchanger or keel cooled configuration.
- Large, easy fill expansion tank.
- Cast iron exhaust manifold is freshwater cooled for safety. No hot, dry risers.
- Zinc anode electrolysis protection.
- Heat exchanger cooling includes: Easy to clean tube-type heat exchanger. Jabsco raw water pump of bronze and stainless steel is accessible. Gear driven pump requires no drive belts.

Fuel System

- Fuel system is self-venting.
- Direct injection for fuel economy, clean exhaust and fast starting.
- Bosch-type in-line injection pump with 5% mechanical governor for close AC output frequency control.
- Hole type injectors. Replaceable tips.
- Mechanical fuel lift pump with hand primer.
- Large spin-on fuel filter.
- Flexible fuel lines routed to base.
- Stop solenoid controls fuel rack, not throttle, for fast engine shutdowns.

Lubrication System

- Full flow, spin-on oil filter with bypass.
- Large capacity, center well oil pan.
- Lube oil drain for quick oil changes.

DC Electrical System

- 12 volt starter and battery charging alternator with regulator.
- Standard panel: Remote mount S-3C with gauges for oil pressure, water temperature, hours and DC voltage.
- Optional: S-4 panel has engine instruments plus AC meters.
- 20 ft plug-in panel harness lets you monitor your set from the bridge. Better than unit mount panels that are prone to vibration problems. Harness extensions and Y's for multi-panel systems are available.
- For safety, low oil pressure, high water temperature and high exhaust temperature shutdowns are standard.



AC Generator

- Northern Lights direct coupled, brushless AC generator is maintenance free.
- 4 lead/1 phase for 50 or 60 hertz AC power output is standard. 12 wire/3 phase generator available.
- Generator features: high quality Class H insulation, accessible diodes, oversized bearings and junction box for AC wiring connections.
- Automatic voltage regulator gives quick response to load changes. Voltage regulated to ± 1% RMS no load to full load.

Special Equipment

- Steel base frame with drip pan.
- Vibration isolation mounts for smooth, quiet operation.
- Closed circuit crankcase vent recycles oil vapors for a cleaner engine room.
- Belt guard standard.
- White polyurethane paint.
- Parts and operator's manuals.



PTO Versatility

- Optional B-spline 2 or 4 bolt, front power take-off with 12 or 24 volt electric clutch. Take up to 42 hp to run your bow thruster, sail handling, deck winches and other shipboard hydraulic equipment.

Optional Sound Enclosure

Maximize your onboard comfort. Powder coated marine aluminum panels lined with foam deaden noise yet allow service access. L 59.51" (1607 mm) x W 30.75" (781 mm) x H 32.13" (816 mm). Weight: 190 lbs. (86 kg).



Dealer:



Manufactured by: **Alaska Diesel Electric, Inc.**

P.O. Box 70543, Seattle, WA 98107

Tel: (206) 789-3880 • 1-800-762-0165 • Fax: (206) 782-5455

Web: www.northern-lights.com • E-mail: ade@northern-lights.com

Information, specifications, materials and dimensions subject to change without notice. © 1999 All rights reserved. Litho in USA. L580 12/99